

PAB & PAF

INTERVAL TIMERS

Industrial Timer Company
 30 Industrial Park Road
 Centerbrook, CT 06409
 800-394-7130
www.industrialtimercompany.com



DESCRIPTION

The PAB and PAF Series timers are rugged, high precision, hard wired interval timers, featuring automatic reset and an infinite resolution clutch. Both units feature an internal holding circuit allowing the use of a momentary start button and, if desired, an emergency stop switch. Both have an isolated single pole, double throw load switch. The PAB is in a housing designed for surface mounting while the PAF is panel mounted.

APPLICATION

These timers are designed for applications requiring high repetitive accuracy, fast reset and heavy usage. Typical applications include oven controls and automatic machinery as well as packaging machinery.

OPERATION

- 1) To set the duration of the interval, set the selector knob to the desired time.
- 2) To start the time interval, close the customer supplied momentary switch connecting power to the CL-2 terminal.
- 3) At the *start* of the time interval, the relay in the timer will change state. At the *end* of the time interval, the relay will change back and the timer will reset automatically.
- 4) To start the time interval again, wait for the timer to reset and close the switch supplying power to the CL-2 terminal.
- 5) To terminate the cycle during timing, activate the customer supplied stop switch. The load contacts will transfer and the unit will automatically reset.

SPECIFICATIONS

Repeat Accuracy	±0.25% of full scale (with motor running continuously)
Reset Time	0.5 seconds max at full setting.
Load Switch Contacts	Isolated SPDT switch rated at 20 amps at 125, 250, or 480 VAC with non-inductive load.
Wiring	Screw type terminal block
Voltage	120V/60Hz standard. Consult factory for other voltages and frequencies.
Agency Approval	PAB, CSA

STANDARD MODELS

Model Number	Maximum Time Cycle	Dial Division
PAF-15S PAB-15S	15 sec	¼ sec.
PAF-30S PAB-30S	30 sec.	½ sec.
PAF-60S PAB-60S	60 sec.	1 sec.
PAF-3M PAB-3M	3 min.	3 sec.
PAF-5M PAB-5M	5 min.	5 sec.
PAF-15M PAB-15M	15 min.	15 sec.
PAF-30M PAB-30M	30 min.	30 sec.
PAF-60M PAB-60M	60 min.	60 sec.
PAF-3H PAB-3H	3 hr.	3 min.

PAB & PAF

INTERVAL TIMERS

PAB DIMENSIONS

Industrial Timer Company

30 Industrial Park Road

Centerbrook, CT 06409

800-394-7130

www.industrialtimercompany.com

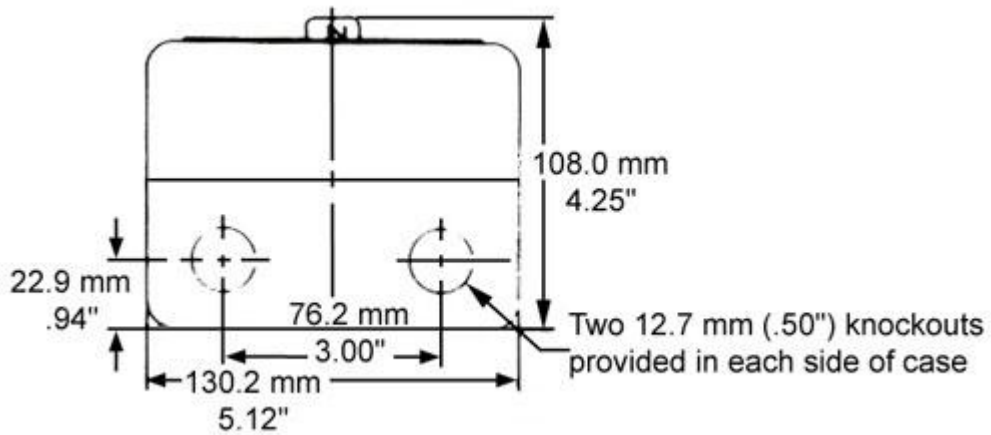
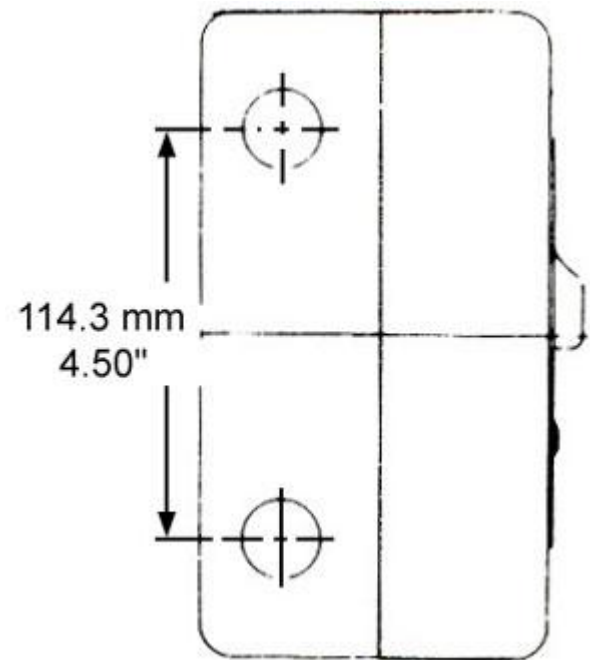
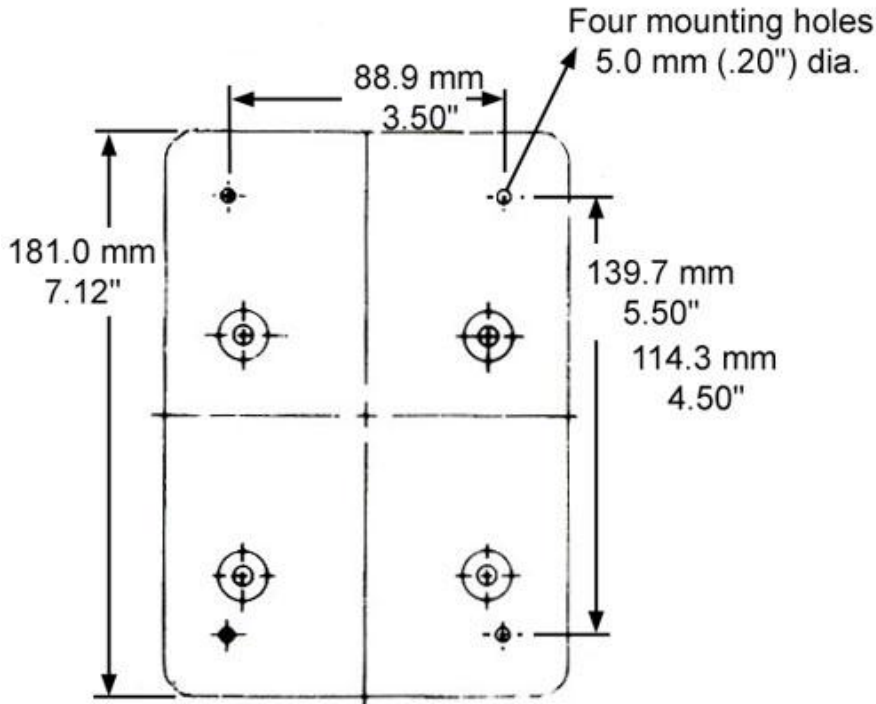

PAB & PAF

INTERVAL TIMERS

Industrial Timer Company

30 Industrial Park Road

Centerbrook, CT 06409

800-394-7130

www.industrialtimercompany.com

PAF DIMENSIONS

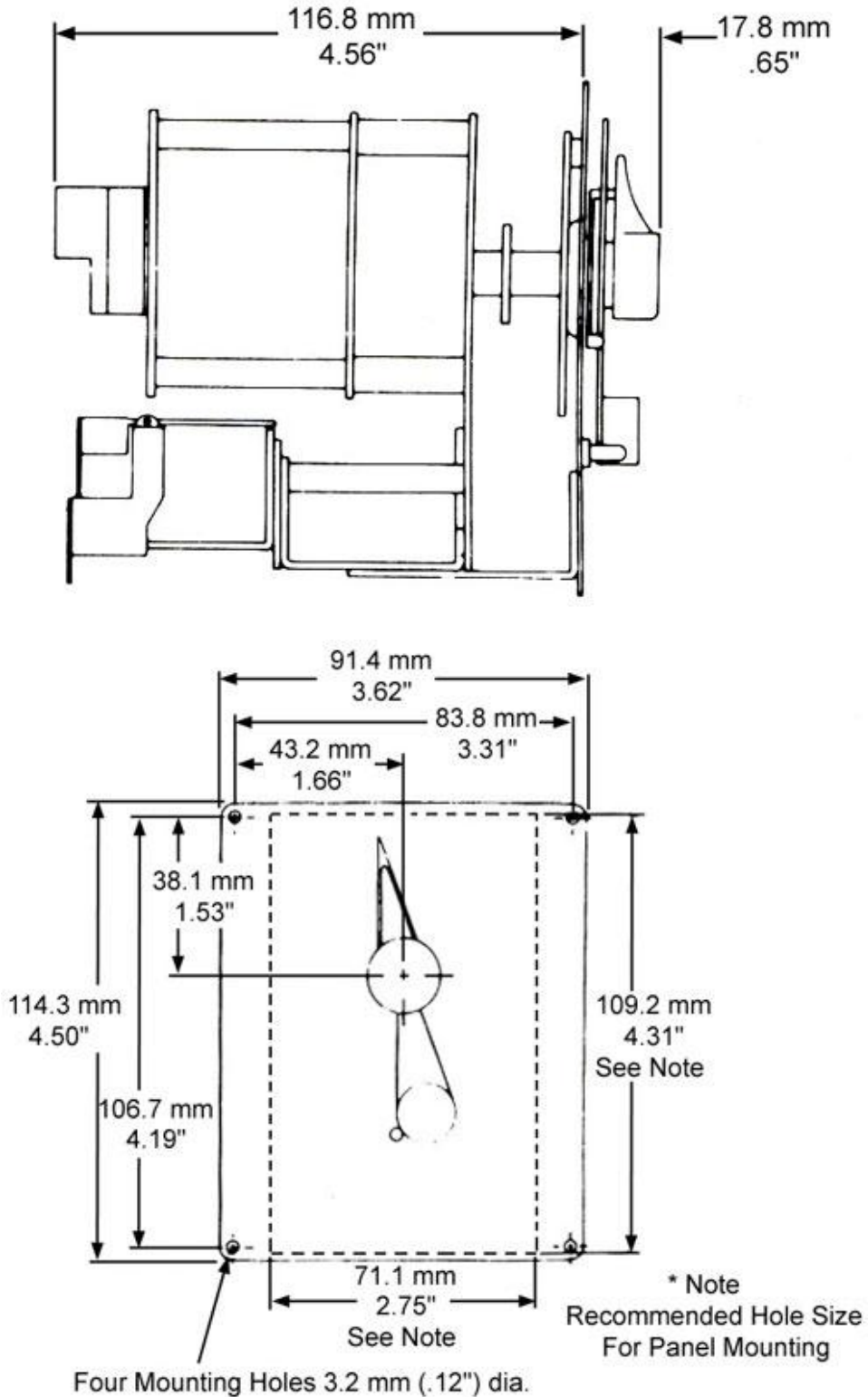

PAB AND PAF WIRING

WIRING TO SINGLE PHASE LOAD

