

P

INTERVAL TIMERS

Industrial Timer Company

30 Industrial Park Road

Centerbrook, CT 06409

800-394-7130

www.industrialtimercompany.com



DESCRIPTION

P series timers are highly portable, high precision interval timers fitted with standard 3-wire power cord and load receptacles. They feature automatic reset, infinite resolution clutch, and either local or remote momentary start. The unit is housed in a sturdy metal case designed for surface mounting. A toggle switch is provided to enable the load to be powered continuously. Both this switch and the load switch are factory wired to input power providing 120 volts AC to the load receptacle.

APPLICATION

These timers are designed for applications requiring high repetitive accuracy combined with portability and ease of connection. Typical applications include: laboratory testing, packaging machinery and coil winding machinery.

OPERATION

- 1) To power the load continuously, put the toggle switch in the *Constant Output* position.
- 2) To activate the timer, put the toggle switch in the *Timed Output* position.
- 3) To set the duration of the interval, set selector to the desired time.
- 4) To start the time interval, press the black button on the front of the unit or close the customer supplied momentary start button.
- 5) At the *start* of the time interval, the relay in the timer will change state, providing power to the load. At the *end* of the time interval, the relay will change back and the timer will reset.
- 6) To start the time interval again, repeat Step No. 4.

SPECIFICATIONS

Repeat Accuracy	±0.25% of full scale (with motor running continuously)
Reset Time	0.5 seconds max at full setting.
Load Switch Contacts	Isolated SPDT switch rated 15 amps at 120 volts with non-inductive load.
Wiring	Standard 3-wire plugs and receptacles
Voltage	120V/60Hz standard. Consult factory for other voltages and frequencies.
Agency Approval	CSA

STANDARD MODELS

Model Number	Maximum Time Cycle	Dial Division
P-15S	15 sec	¼ sec.
P-30S	30 sec.	½ sec.
P-60S	60 sec.	1 sec.
P-3M	3 min.	3 sec.
P-5M	5 min.	5 sec.
P-15M	15 min.	15 sec.
P-30M	30 min.	30 sec.
P-60M	60 min.	60 sec.
P-3H	3 hr.	3 min.

P

INTERVAL TIMERS

DIMENSIONS

Industrial Timer Company

30 Industrial Park Road

Centerbrook, CT 06409

800-394-7130

www.industrialtimercompany.com

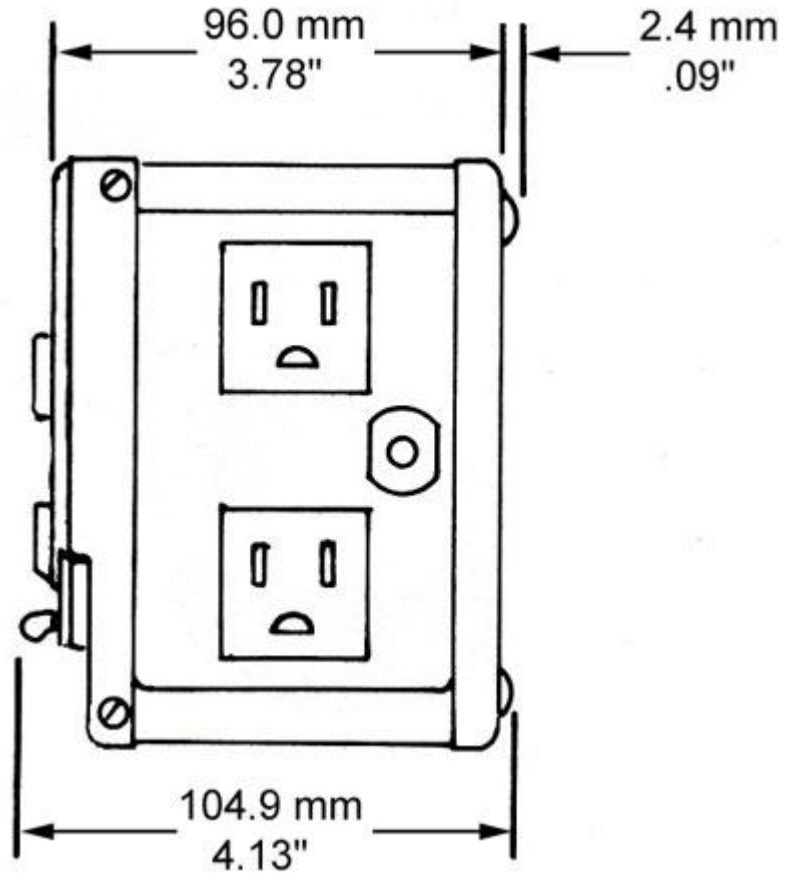

P

INTERVAL TIMERS

DIMENSIONS (CONTINUED)

Industrial Timer Company
30 Industrial Park Road
Centerbrook, CT 06409
800-394-7130
www.industrialtimercompany.com

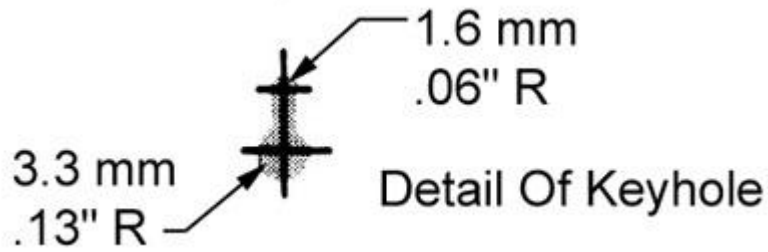
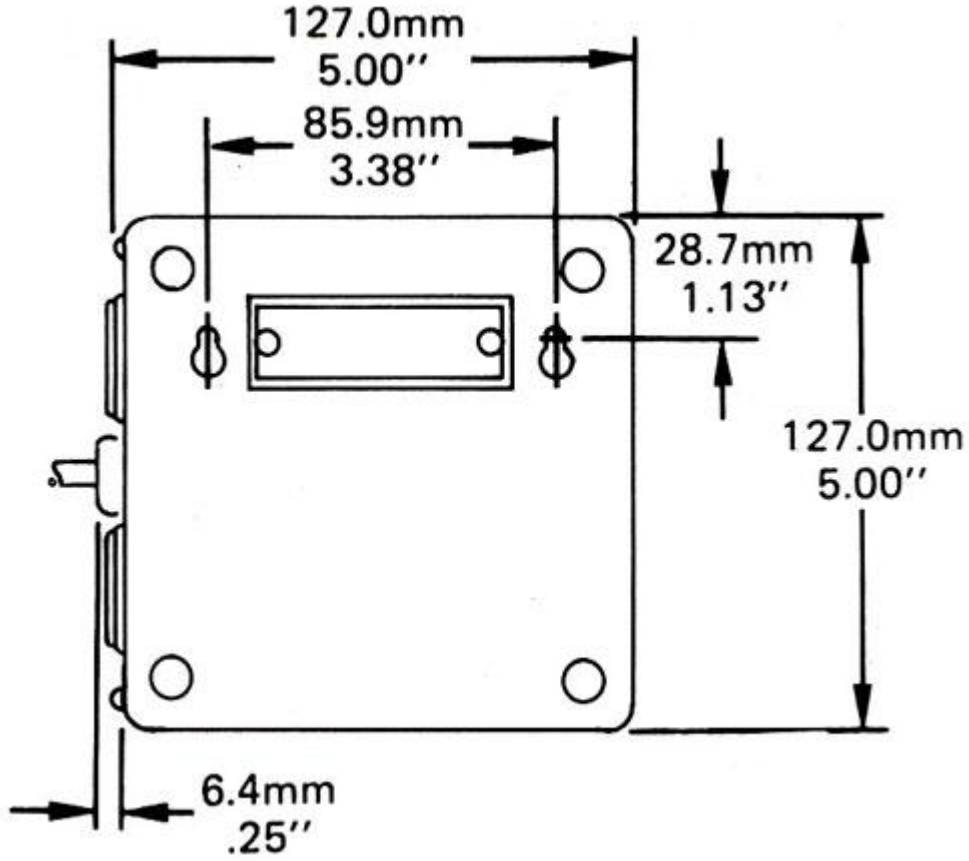

P

INTERVAL TIMERS

WIRING ARRANGEMENT (STANDARD)

Industrial Timer Company
30 Industrial Park Road
Centerbrook, CT 06409
800-394-7130
www.industrialtimercompany.com

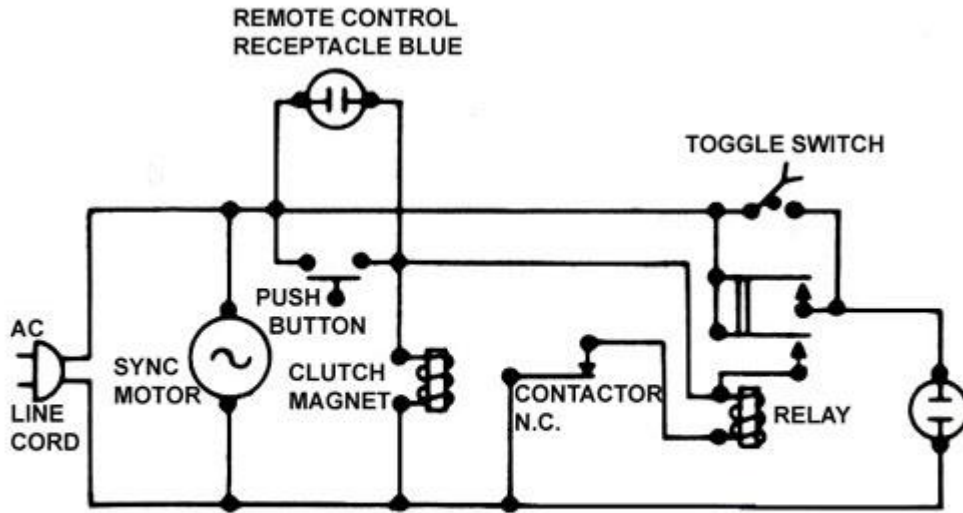

**FIGURE 1 CONTACTS
LOAD RECEPTACLE BLACK**